

**NEWSMITH**

**BATCH GALAXY  
MULTI-PURPOSE  
WASHER**

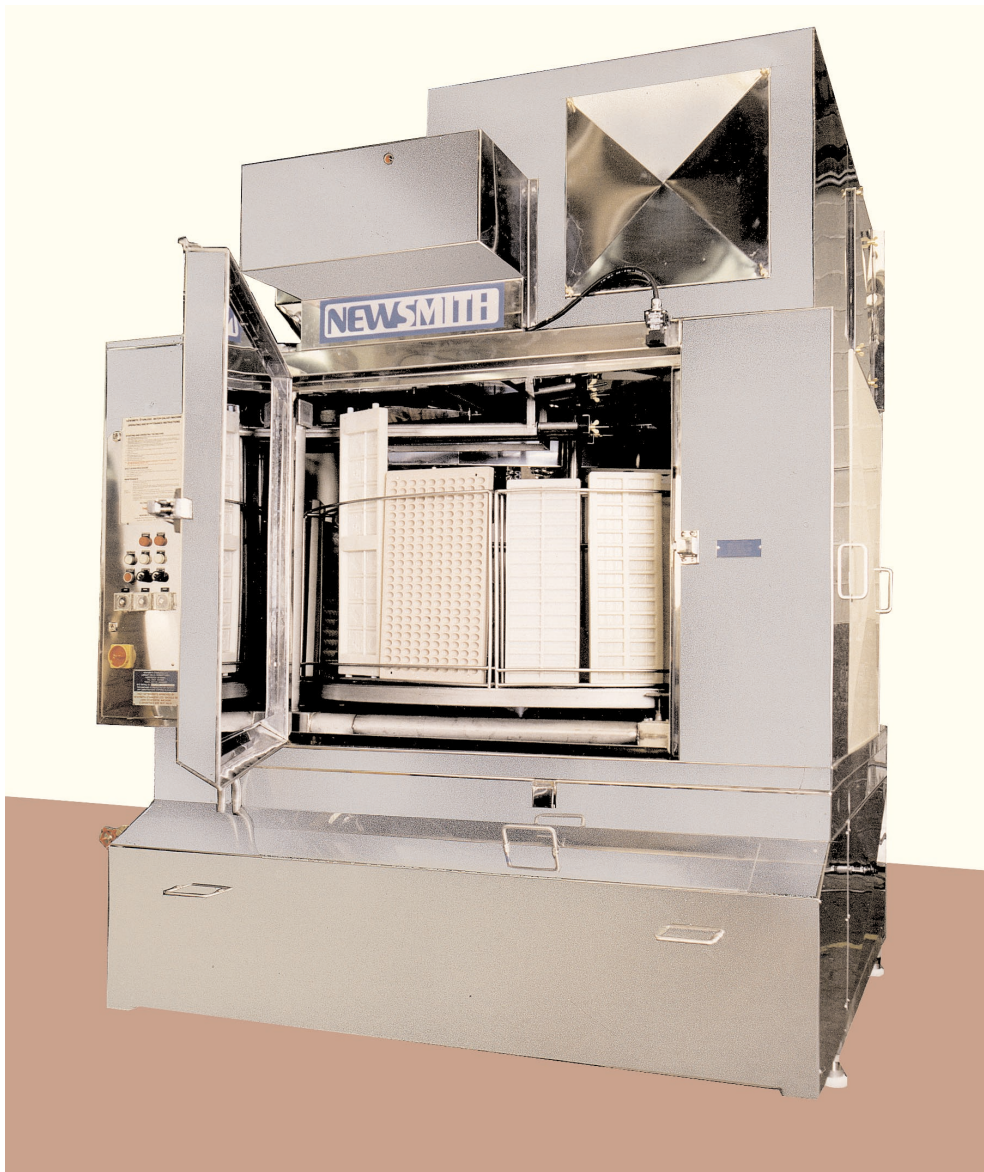

**TIME • ENERGY  
MONEY SAVERS**

# TECHNICAL SPECIFICATION

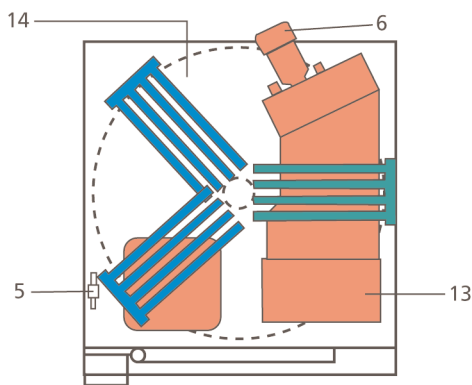
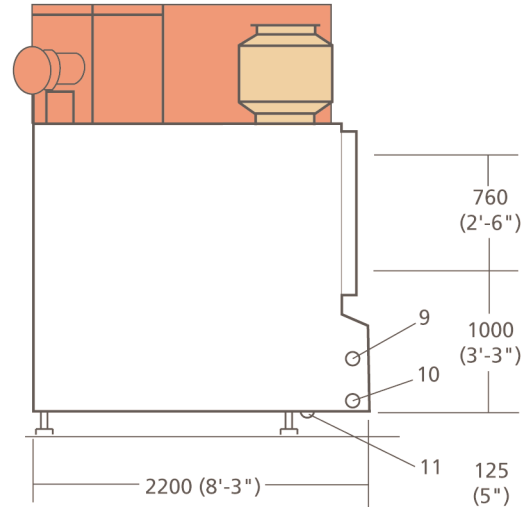
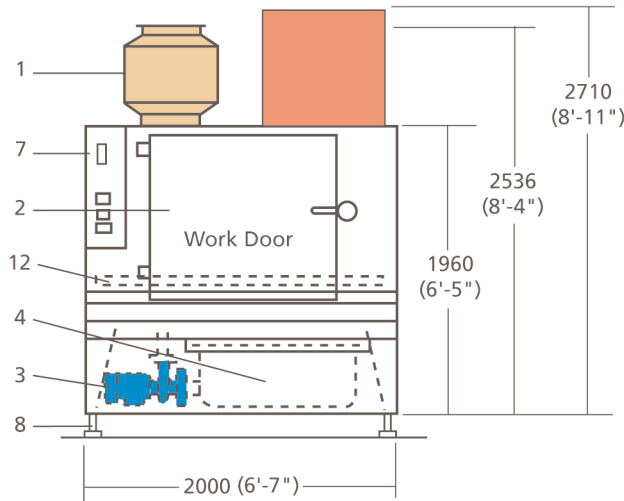

- |                               |                         |
|-------------------------------|-------------------------|
| 1. Extract Fan (optional)     | 8. Adjustable Legs      |
| 2. Hinged Door                | 9. Steam/gas Connection |
| 3. Wash Pump                  | 10. Water Connection    |
| 4. detergent Tank             | 11. Drain Connection    |
| 5. Rinse Solenoid Valve (hot) | 12. Rotating Work table |
| 6. Dryer Fan Motor (optional) | 13. Dryer Heater        |
| 7. Timer Selection Block      | 14. Table Drive         |

 DETERGENT WASH JETTING

 RINSE JETTING DOMESTIC HOT

 DRYER

EXTRACT FAN 

Constructed throughout in stainless steel, including stainless steel jet pipes, stainless steel tank heating elements.

#### WASH PUMP

The wash pump is a 5½ kW (7½ h.p.) unit.

#### WASH PIPES AND NOZZLES

The wash pipes are manufactured in stainless steel with specially designed stainless steel cutting nozzles.

#### FRESH WATER RINSE

Fresh water rinse piping is in stainless steel, arranged with nozzles complete with a strainer and solenoid valve taking the rinse direct from the mains supply.

#### DRYER (Optional)

Stainless steel construction, including fan.

#### ROTARY TABLE

The 6'-0" diameter (larger special sizes available) ring type conveyor is of rugged stainless steel construction, arranged with slots to accommodate thin work or special fixtures.

#### TANK HEATING

The machine is arranged for direct steam heating, steam coil, gas or electric.

#### FILTERS

The wash tank is fitted with a very large stainless steel filter tray which can be fitted with a limit switch to ensure No Filter - No Wash Pump working. Full automatic filtration options are available.

#### MOTOR CONTROLS & WIRING

The stainless steel control panel accommodates a starter for the wash pump, complete with overloads and three timers, i.e. Wash timer, Rinse timer and Dryer timer.

#### ESTIMATED SERVICE REQUIREMENTS

Total electrical load, including table drive and dryer fan: 11kW (15 h.p.).

Steam consumption, approximately 250 lbs/hour.

Water consumption, approximately 10 gallons/batch.

#### OPTIONAL EQUIPMENT

Steam extract fan.

Special work racks.

Booster tank (for increased rinse temperature and pressure).

Steam coil heating.

Filter basket limit switch.

Stainless steel duct work to atmosphere.

*Due to continuous technical developments, specifications may be modified without notice.*



#### NEWSMITH STAINLESS LIMITED

Fountain Works, Child Lane, Roberttown, Liversedge, West Yorkshire WF15 7PH United Kingdom

Tel: +44 (0)1924 405988 Fax: +44 (0)1924 403304

Email: sales@newsmiths.co.uk www.newsmiths.co.uk